

UDC 678.4.06:621.81

DOI: <https://doi.org/10.1051/e3sconf/201910900052>

ON THE OSCILLATIONS OF SPATIAL VIBRATION-ISOLATING SYSTEM OF MINING MACHINES UNDER THE ACTION OF IMPACT LOADS

¹*Lysytsia M.I.*¹*Institute of Geotechnical Mechanics named by N. Poljakov of NAS of Ukraine*

ПРО КОЛИВАННЯ ПРОСТОРОВОЇ ВІБРОІЗОЛЯЦІЙНОЇ СИСТЕМИ ГІРНИЧИХ МАШИН ПІД ДІЮ ПРИКЛАДЕНИХ НАВАНТАЖЕНЬ

¹*Лисиця М.І.*¹*Інститут геотехнічної механіки ім. М.С. Полякова НАН України*

О КОЛЕБАНИЯХ ПРОСТРАНСТВЕННОЙ ВИБРОИЗОЛИРУЮЩЕЙ СИСТЕМЫ ГОРНЫХ МАШИН ПОД ДЕЙСТВИЕМ ПРИЛОЖЕННЫХ НАГРУЗОК

¹*Лисица Н.И.*¹*Институт геотехнической механики им. Н.С. Полякова НАН Украины*

Abstract. The main factor holding back the introduction of belt conveyors for transporting bulk cargo is the low life of the belt and rollers, caused by significant dynamic forces at the loading points. In the interaction of pieces of cargo with an elastically mounted roller support, the impact process consists of two phases: the collision, which is considered as the impact of free bodies, and the subsequent movement of the supporting structures at a certain initial speed. After impact, the load roller oscillate about the equilibrium position. When the next piece of cargo falls due to the oscillation of the roller support, the relative speed of interaction of the bodies (load - roller support) may increase or decrease compared with the case of the initial impact. To reduce the load on the belt and the rollers necessary to the settling time of the suspension system was less than the period of passage of large pieces.

The paper considers the influence of the type of loading sections of the belt conveyor on the nature of the movement of the roller bearings after interacting with bulk cargo. The oscillations of two main types of loading sections are studied - with load-bearing ropes and compliant roller bearings of the design of IGTM of NAS of Ukraine.

A distinctive feature of the IGTM compliant roller bearings is special bearing rollers, which are pivotally attached at one end to the side posts and the other to ropes stretched along the conveyor section. Standard clips are embedded in the frames. In the middle between the side rollers on the ropes, frames for the middle rollers are attached. The tension of the ropes is carried out by a screw device.

A mechanism has been established to reduce the amplitude of the oscillations of the rollers of the loading section as compared with the initial displacement after the impact, which consists in the fact that at the first moment of time, under the influence of the falling load, the deflection is localized over the small length of the section, and subsequently the energy accumulated by this section is spent on fluctuations along the length of the entire section.

The rational parameters of the loading section (length, rope tension, stiffness, distance between the rollers) are determined, at which the amplitude of the vertical vibrations of the roller decreases 6-8 times in a time of 0.4-0.5 s.

Keywords: loading section, impact, bulk cargo, belt conveyor

1 Introduction

Since conveyor transport is high-productive, it is the integral part of schemes of cyclic and continuous flow process technology as well as continuous flow process technology in mining. Loading of lumpy product and its conveyance is the restricting factor to apply belt conveyers efficiently.

Currently, loading sections of belt conveyers with the use of steel ropes to support rollers and carrying rollers are very popular.

Effect of lumpy product on carrying rollers of loading section of a conveyor is characterized by pressure of dice load as well as impact of lumps with certain time interval. After the lump impact, carrying rollers of the section oscillate relative to balance position. When following lump is falling, relative velocity of interaction of the bodies (i.e. load-carrying roller) may either increase or decrease to compare with the initial impact due to carrying roller oscillations. The fact results in the increased dynamic loads both

on the belt and the carrying rollers. To decrease the loads, it is necessary for time of suspension system of carrying rollers balancing to be less than a period during which lumps pass. In this context, it is necessary to know displacement mode of carrying rollers, and determine effect of structure of the section and its parameters on its displacement mode in time.

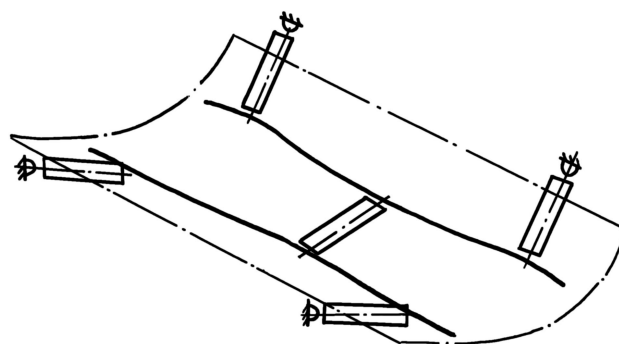

Figure 1 – Section of nonrigid carrying rollers

Consideration of the problem is of prime importance while designing supporting loading elements taking into consideration a flow of the material being loaded.

The paper analyzed oscillations of the two basic types of loading sections – with conveying ropes, and nonrigid carrying rollers designed by Institute of Geotechnical Mechanics named by N. Poljakov of National Academy of Sciences of Ukraine (Fig. 1).

2 Theoretical study

While forming oscillation equation of nonrigid carrying roller section, the following has been hypothesized: movement value of central roller cannot depend upon load point along the section length, and longitudinal movements of the rollers are more than by an order of magnitude lesser than vertical ones; and when nonrigid carrying rollers interact with a lump, rope tension varies if only suspension achieves its maximum displacement. Further oscillations of the section take place in terms of practically constant rope tension. That makes it possible to consider a section of nonrigid carrying rollers as a constant density string on an elastic foundation; in this context, at a first approximation, damping of the system is not considered.

Figure 2,a demonstrates analytical model where U is string deviation from its balance; L is string length; T and ρ are string tension and linear density respectively; and C_0 is rigidity coefficient of the elastic foundation. Figure 2,b shows original form of the string bend where b is distance between central rollers and h is the string bend. Original form of the string bend depends upon design features of the section of nonrigid carrying rollers; moreover, experimental data confirm the fact.

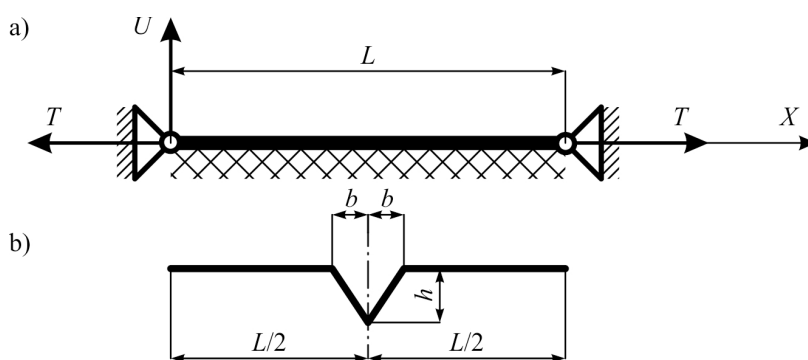

Figure 2 – Analytical model of a section of nonrigid carrying rollers

Using the principles of d'Alembert [1] for the string section we obtain the equations of oscillations:

$$\frac{\partial^2 U}{\partial x^2} = \beta^2 \frac{\partial^2 U}{\partial t^2} + k^2 U, \quad (1)$$

where $\beta^2 = \frac{\rho}{T}$; $k^2 = \frac{C_0}{T}$,

in terms of following initial conditions:

$$U(x,0) = \begin{cases} 0, & 0 < x < \frac{L}{2} - b; \\ -\frac{h}{b}x + \frac{h}{b}\left(\frac{L}{2} - b\right), & \frac{L}{2} - b < x < \frac{L}{2}; \\ \frac{h}{b}x - \frac{h}{b}\left(\frac{L}{2} + b\right), & \frac{L}{2} < x < \frac{L}{2} + b; \\ 0, & \frac{L}{2} + b < x < L; \end{cases} \quad (2)$$

$$\frac{\partial U(x,0)}{\partial t} = 0$$

and boundary conditions:

$$\begin{aligned} U(0,t) &= 0; \\ U(L,t) &= 0. \end{aligned} \quad (3)$$

The solution of equation (1) by the Fourier method is presented in general form:

$$U(x,t) = X(x)T(t), \quad (4)$$

where

$$\begin{aligned} X(x) &= A \cos(\sqrt{\lambda}x) + B \sin(\sqrt{\lambda}x); \\ T(t) &= C_n \cos\left(\sqrt{\frac{k^2}{\beta^2} + \frac{\lambda}{\beta^2}} \cdot t\right) + D_n \sin\left(\sqrt{\frac{k^2}{\beta^2} + \frac{\lambda}{\beta^2}} \cdot t\right); \\ \lambda &= \left(\frac{\pi n}{L}\right)^2, \quad (n = 1, 2, 3 \dots), \end{aligned} \quad (5)$$

A, B, C_n, D_n – arbitrary constants.

Insert expression (5) into equation (4). While using conditions (2), and (3) we obtain:

$$U(x,t) = \sin\left(\frac{n\pi}{L}x\right) \left\{ C_n \cos\left[\sqrt{\left(\frac{k}{\beta}\right)^2 + \left(\frac{n\pi}{L\beta}\right)^2} \cdot t\right] + D_n \sin\left[\sqrt{\left(\frac{k}{\beta}\right)^2 + \left(\frac{n\pi}{L\beta}\right)^2} \cdot t\right] \right\}.$$

Relying upon $\frac{\partial U(x,0)}{\partial t} = 0$ condition, we identify that $D_n = 0$.

Then,

$$U(x,t) = \sum_{n=1}^{\infty} C_n \cos\left[\sqrt{\left(\frac{k}{\beta}\right)^2 + \left(\frac{n\pi}{L\beta}\right)^2} \cdot t\right] \sin\left(\frac{n\pi}{L}x\right). \quad (6)$$

In terms of equation (9), constant C_n is determined using the expression:

$$C_n = \frac{2}{L} \int_0^L f(x) \sin\left(\frac{n\pi}{L}x\right) dx, \quad (7)$$

where $f(x)$ is a function corresponding to initial conditions (2).

It follows from initial conditions (2) that:

$$f(x) = \begin{cases} 0, & 0 \leq x < \frac{L}{2} - b; \\ -\frac{h}{b}x + \frac{h}{b}\left(\frac{L}{2} - b\right), & \frac{L}{2} - b \leq x < \frac{L}{2}; \\ \frac{h}{b}x - \frac{h}{b}\left(\frac{L}{2} + b\right), & \frac{L}{2} \leq x < \frac{L}{2} + b; \\ 0, & \frac{L}{2} + b \leq x < L. \end{cases} \quad (8)$$

Inserting expressions (8) into (7), we obtain

$$C_n = \frac{8hL}{b^2\pi^2n^2} \sin\left(\frac{n\pi}{2}\right) \sin^2\left(\frac{n\pi b}{2L}\right). \quad (9)$$

Taking into consideration that $\beta^2 = \rho/T$, and inserting (9) into (6), we obtain definitely:

$$U(x,t) = -\frac{8hL}{b\pi^2} \sum_{n=1}^{\infty} \frac{1}{n^2} \sin^2\left(\frac{n\pi b}{2L}\right) \sin\frac{n\pi}{2} \cos\left[\sqrt{\frac{C_0}{\rho} + \frac{T}{\rho L^2}}(n\pi)^2 \cdot t\right] \sin\left(\frac{n\pi}{L}x\right). \quad (10)$$

According to [2], rigidity coefficient of elastic foundation is determined using the expression

$$C_0 = \frac{p}{fb},$$

where p is a load acting on the roller; and f is displacement of the roller under the load action.

Consider oscillations of loading section with conveying ropes. In this context, boundary conditions remain previous ones, and initial conditions are:

$$U(x,t) = \begin{cases} -\frac{2h}{L}x, & 0 < x < \frac{L}{2}; \\ \frac{2h}{L}(x-L), & \frac{L}{2} < x < L; \end{cases} \quad (11)$$

$$\frac{\partial U(x,0)}{\partial t} = 0.$$

If initial boundaries (11), and boundary ones (3) are taken into consideration, then solution of equation (1) is

$$U(x,t) = -\frac{8h}{\pi^2} \sum_{n=1}^{\infty} \frac{1}{n^2} \sin\left(\frac{n\pi}{2}\right) \cos\left[\sqrt{\frac{C_0}{\rho} + \frac{T}{\rho L^2}}(n\pi)^2 \cdot t\right] \sin\left(\frac{n\pi}{L}x\right). \quad (12)$$

Hence, expressions have been developed to determine displacements of loading section points for nonrigid carrying rollers (10), and sections with conveying ropes (12).

We will analyze the solutions obtained.

Study the effect of loading section length, and initial deviation nature on its oscillation mode within a point of maximum bend, i.e. if $x = L/2$, and $U(x, 0) = -h$.

1. Suppose that $L = 2b$, i.e. initial deviation corresponds to (11) conditions. Then, expression (10) is

$$U\left(\frac{L}{2}, t\right) = -\frac{16h}{\pi^2} \sum_{n=1}^{\infty} \frac{1}{n^2} \sin^2(n\pi) \cos\left[\sqrt{\frac{C_0}{\rho} + \frac{T}{\rho L^2}(n\pi)^2} \cdot t\right] \sin^2\left(\frac{n\pi}{2}\right). \quad (13)$$

If n values are even ones, then expression (13) is equal to 0. If n values are odd ones, then $\sin^2 \frac{n\pi}{2} = \frac{1}{2}$. Hence, expression (13) is as follows

$$U\left(\frac{L}{2}, t\right) = -\frac{8h}{\pi^2} \sum_{n=1}^{\infty} \frac{1}{n^2} \sin^2\left(\frac{n\pi}{2}\right) \cos\left[\sqrt{\frac{C_0}{\rho} + \frac{T}{\rho L^2}(n\pi)^2} \cdot t\right].$$

The generated dependence coincides completely with expression (12) for section with conveying ropes.

In accordance with (12), string points with coordinate $x = L/2$ oscillate harmonically with following frequency

$$\omega = \sqrt{\frac{C_0}{\rho} + \frac{T}{\rho L^2}(n\pi)^2}$$

and amplitude being equal to $\pm 8h/\pi^2$.

While setting $C_0 = 0$ in (12), we arrive at the known expression of oscillations of finite-length string with fixed ends [1].

2. Determine displacement if $L \rightarrow \infty$. While applying L'Hospital rule, we identify that

$$U\left(\frac{L}{2}, t\right) = \lim_{L \rightarrow \infty} \frac{\left[\sum_{n=1}^{\infty} \frac{1}{n^2} \sin^2\left(\frac{n\pi}{2} \frac{b}{L}\right)\right]^{11}}{\left(\frac{b\pi^2}{8hL}\right)^{11}} = 0,$$

i.e. in terms of considerable L , oscillations of sections decay within a point of maximum bend.

Calculations on formula (10) have been performed to determine effect of the section parameters on its oscillations. The section parameters varied as follows: distance between rollers b was 0.8 and 1.0 m; rope tension T was 6.0; 8.0 and 10.0 kN; section length L was 5; 10; 15 and 20 m; linear density ρ – 50; 80; 110 kg/m; rigidity of nonrigid carrying rollers C was 60.0; 90; 120 and 150 kN/m² and initial deviation was $h = 0.09$ m.

The number of series terms was determined with 10 % calculation accuracy and amounted 11; 21; 31 and 43 respectively for such section lengths as 5; 10; 15 and 20 m. For 1 % calculation accuracy, 129, 257 and 385 series terms ($L = 5; 10; 15$ m) required

respectively. However, comparison of the obtained results has shown that the number of series terms effects calculation accuracy of initial ratio h at $t = 0$ time moment. If $t > 0$, then displacement calculation divergence is up to 1.5 %.

The calculations results helped construct graphs of vertical displacements of the section in time if its parameters vary.

Figure 3, a, demonstrates graphs of lateral oscillations of the sections in terms of its varied length as well as rigidity (Fig. 3, b) of elastic foundation. The graphs explain that in the course of time, the section oscillates with constant amplitude decreasing along with the increase in the section length. To compare with the initial disturbance, the amplitude decrease of subsequent oscillations is connected with the fact that at $t = 0$ time moment, deviation from the balance concerns limited section area only. Then, the whole its length is involved in the oscillations. Analysis of curves in Figure 3, b shows that the increased rigidity of elastic foundation results in the increase of subsequent oscillations (curve 2). The increased amplitude can be explained by the increased potential energy of the section area with the initial deviation.

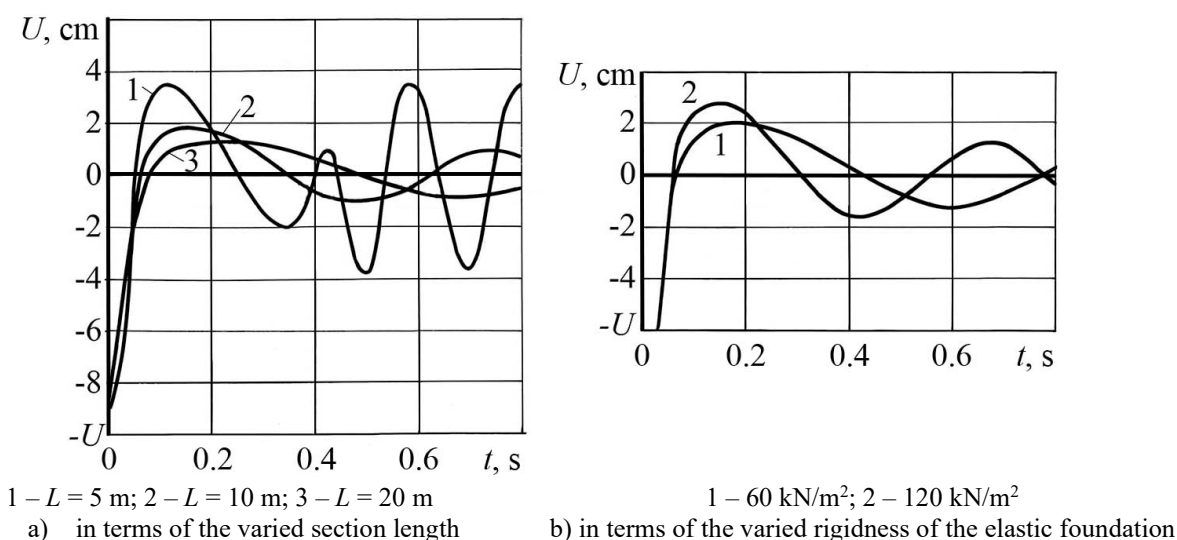

Figure 3 – Graphs of lateral oscillations

Analysis of the calculation results has shown:

- changes in line load has minor effect on the amplitude of subsequent oscillations;
- increase in rope tension decreases amplitude of subsequent oscillations; and
- 1.0 m down to 0.8 m decrease in distance between rollers results in 25-30 % decrease of subsequent section oscillations.

The research has made it possible to determine the effect of the loading section design and parameters on the mechanism of roller displacement reduction in the context of vertical oscillations of the loading section after its interaction with falling material. To compare with initial displacement, the mechanism intended to decrease amplitude of roller oscillation is as follows: during the first time moment, falling load localized bend within a small distance of the section length; subsequently, the energy, accumulated by the area, is consumed by longitudinal oscillations along the section length. Further, point along the section length oscillate. Amplitude of their oscillations is 8-10 times less to compare with the initial deviation amplitude resulted from the load impact. Consideration of frictional losses within the system will result in the damped

oscillations while complicating the solution significantly. However, neither qualitative nor quantitative analysis may involve consideration of the losses.

It has been determined that 6-8 times decrease in amplitude of vertical oscillations of rollers during 0.4-0.5 s is provided owing to following section parameters: length should not be less than 10 m; rope tension should be 8-10 kN, rigidity should be 100-120 kN, and distance between rollers should be 0.7-0.8 m.

3 Experiments

The experiments were carried out by means of a belt conveyor set-up with 80 m length, 0° inclination angle, and 800 mm belt width. Granite was loaded. Its maximum lump size was 400-800 mm; drop height was 0.5 m and 1.0 m; nonrigid carrying rollers were used within loading area.

Objective of the experiments is to substantiate analytical model, and to make qualitative evaluation of the results of theoretical studies as for interaction between load and nonrigid carrying rollers.

Figure 4 demonstrates a scheme of arrangement of sensors within a section of non-rigid carrying rollers. Hereinafter, following symbols are applied:

- $D_1, D_3,$ and D_4 are sensors of vertical displacements of central rollers;
- D_2 is a sensor of vertical displacements of central roller interacting with the falling load;
- $P_1,$ and $P_2, C_1,$ and C_2 are sensors of angular displacements of side rollers;
- $K_1,$ and K_2 rope tension sensors.

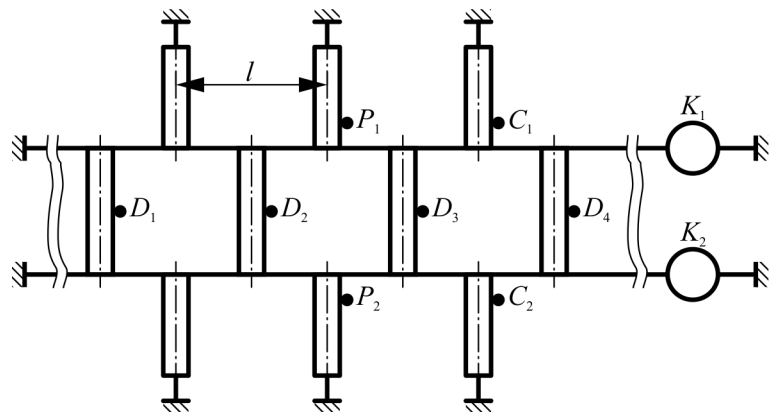

Figure 4 – Scheme of arrangement of sensors

Values of displacement of rollers as well as their oscillation mode after impact with a lump load were determined if variations concerned: loading height (0.5 m; 0.6 m; 0.8 m and 1.0 m); falling lump weight (16 kg and 29 kg); preliminary rope tension (2.0 kN; 3.0 kN; and 4.0 kN and distance between rollers (1 m).

Figure 5 explains interaction of 16 kg lump when rope tension is 4.0 kN.

Analysis of the obtained data shows that after impact, a roller performs rapidly damping oscillations during 0.4-0.5 s. Amplitude value of oscillations, following the interaction, are 6-10 times less to compare with maximum displacement during impact.

Movement of other central rollers (sensors $D_1,$ and D_4) starts when a roller, experiencing the impact (sensor D_2), achieves maximum displacement. Hence, weight of one roller takes place in the impact; loading section bends in terms of length being equal to a twofold pitch of arrangement of rollers. After the interaction, roller oscillations take place in the context of almost constant rope tension. Preliminary rope tension increase results in oscillation amplitude of the roller after interaction.

Availability of a belts is not very important for maximum roller displacements (difference is up to 10 %) having minor effect on the section oscillation mode.

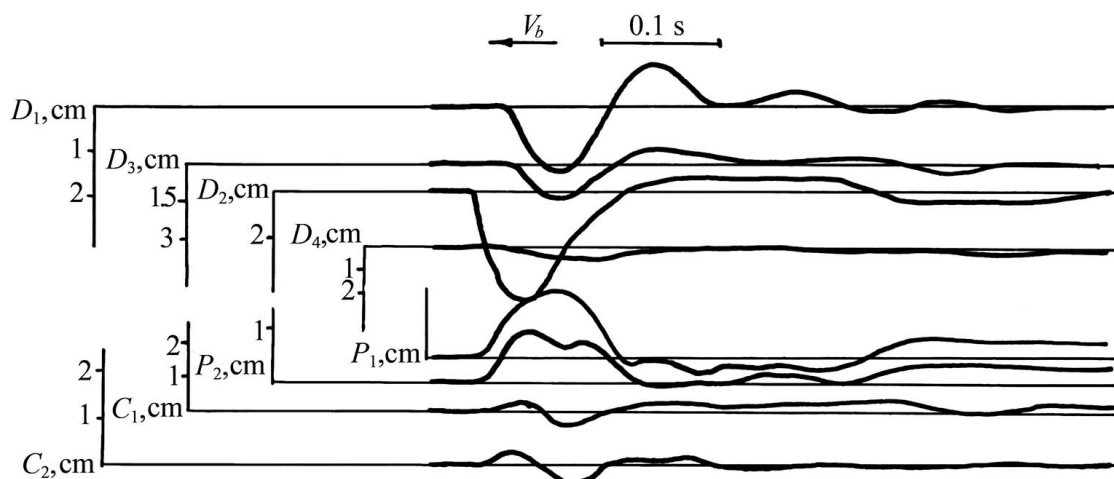

Figure 5 – Oscillograms of interaction between a lump and nonrigid carrying rollers

Conclusions

1. The experiments have confirmed adequacy of the assumptions originated during the analytical model substantiation.
2. The results of theoretical studies, concerning the effect of loading section parameters on the mode of vertical oscillations, and on their amplitude after interaction with a single lump, have been supported.
3. The regularities of oscillation amplitude of a loading section after interaction with a single lump have been identified.

REFERENCES

1. Aramanovich, I.G. and Levin, V.I. (1969), *Uravneniya matematicheskoy fiziki* [Equations of mathematical physics], Nauka, Moscow, USSR.
2. Timoshenko, S.P. (1946), *Soprotivleniye materialov* [Strength of materials], Gostekhizdat, Moscow, USSR.

СПИСОК ЛІТЕРАТУРИ

1. Араманович І.Г., Левин В.І. Уравнения математической физики. М.: Наука, 1969. 288 с.
2. Тимошенко С.П. Сопrotивление материалов. М.: Гостехиздат, 1946. 456 с.

About the authors

Lysytsia Mykola Ivanovych, Candidate of Technical Sciences (Ph. D.), Senior Researcher, Senior Researcher in Department of Elastomeric Component Mechanics in Mining Machines, Institute of Geotechnical Mechanics named by N. Poljakov of National Academy of Science of Ukraine, Dnipro, Ukraine, vita.igtm@gmail.com

Про авторів

Лисиця Микола Іванович, кандидат технічних наук, старший науковий співробітник, старший науковий співробітник відділу механіки еластомерних конструкцій гірничих машин, Інститут геотехнічної механіки ім. М.С. Полякова Національної академії наук України (ІГТМ НАНУ), м. Дніпро, Україна, vita.igtm@gmail.com

Анотація. Основним фактором, що стримує впровадження стрічкових конвеєрів для транспортування крупнокускових вантажів, є низький термін служби стрічки та роликів, викликаний значними динамічними зусиллями в пунктах завантаження. При взаємодії шматків вантажу з пружно встановленою роликоопорою процес удару складається з двох фаз: зіткнення, що розглядається як удар вільних тіл, і подальшого руху підтримуючих конструкцій з деякою початковою швидкістю. Після удару вантажу роликоопори здійснюють коливання щодо положення рівноваги. При падінні наступного шматка вантажу через коливання роликоопор відносна швидкість взаємодії тіл (вантаж – роликоопора) може збільшуватися або зменшуватися в порівнянні з випадком початкового удару. Для зменшення навантажень на стрічку та ролики необхідно, щоб час заспокоєння системи підвіски був менше періоду проходження великих шматків.

У роботі розглянуто вплив типу завантажувальних секцій стрічкового конвеєра на характер руху роликкоопор після взаємодії з крупнокусковим вантажем. Досліджено коливання двох основних типів завантажувальних секцій – з несучими канатами та податливими роликкооперами конструкції ІГТМ НАН України.

Встановлено механізм зменшення амплітуди коливань роликів завантажувальної секції в порівнянні з початковим переміщенням після удару, який полягає в тому, що в перший момент часу під дією падаючого вантажу прогин локалізується на малій довжині ділянки секції, а в подальшому енергія, накопичена цією ділянкою, витрачається на позовжні коливання по довжині всієї секції.

Визначено раціональні параметри завантажувальної секції (довжина, натяг канатів, жорсткість, відстань між роликами), при яких амплітуда вертикальних коливань ролика зменшується в 6-8 разів за час 0,4-0,5 с.

Ключові слова: завантажувальна секція, удар, крупнокусковий вантаж, стрічковий конвеєр

Аннотация. Основным фактором, сдерживающим внедрение ленточных конвейеров для транспортирования крупнокусковых грузов, является низкий срок службы ленты и роликов, вызванный значительными динамическими усилиями в пунктах погрузки. При взаимодействии кусков груза с упруго установленной роликкоопорой процесс удара состоит из двух фаз: соударения, рассматриваемого как удар свободных тел, и последующего движения поддерживающих конструкций с некоторой начальной скоростью. После удара груза роликкоопоры совершают колебания относительно положения равновесия. При падении следующего куска груза из-за колебания роликкоопор относительная скорость взаимодействия тел (груз – роликкоопора) может увеличиваться или уменьшаться по сравнению со случаем первоначального удара. Для уменьшения нагрузок на ленту и ролики необходимо, чтобы время успокоения системы подвески было меньше периода прохождения крупных кусков.

В работе рассмотрено влияние типа загрузочных секций ленточного конвейера на характер движения роликкоопор после взаимодействия с крупнокусковым грузом. Исследованы колебания двух основных типов загрузочных секций – с несучими канатами и податливыми роликкооперами конструкции ІГТМ НАН України.

Отличительная особенность податливых роликкоопор ІГТМ – специальные несущие ролики, которые шарнирно прикреплены одним концом к боковым стойкам, а другим – к канатам, натянутым вдоль секции конвейера. В рамки вкладываются стандартные ролики. Посередине между боковыми роликами на канатах крепятся рамки для средних роликов. Натяжение канатов осуществляется винтовым устройством.

Установлен механизм уменьшения амплитуды колебаний роликов загрузочной секции по сравнению с первоначальным перемещением после удара, который заключается в том, что в первый момент времени под действием падающего груза прогиб локализуется на малой длине участка секции, а в дальнейшем энергия, накопленная этим участком, расходуется на продольные колебания по длине всей секции.

Определены рациональные параметры загрузочной секции (длина, натяжение канатов, жёсткость, расстояние между роликами), при которых амплитуда вертикальных колебаний ролика уменьшается в 6-8 раз за время 0,4-0,5 с.

Ключевые слова: загрузочная секция, удар, крупнокусковой груз, ленточный конвейер

Статья поступила в редакцию 10.02.2020

Рекомендовано к печати д-ром техн. наук В.П. Надутым